

EK-0TU58-UG-001

**TU58 DECtape II
User's Guide**

1st Edition, October 1978

The drawings and specifications herein are the property of Digital Equipment Corporation and shall not be reproduced or copied or used in whole or in part as the basis for the manufacture or sale of equipment described herein without written permission.

Copyright © 1978 by Digital Equipment Corporation

The material in this manual is for informational purposes and is subject to change without notice. Digital Equipment Corporation assumes no responsibility for any errors which may appear in this manual.

Printed in U.S.A.

This document was set on DIGITAL's DECset-8000 computerized typesetting system.

The following are trademarks of Digital Equipment Corporation, Maynard, Massachusetts:

DIGITAL
DEC
PDP
DECUS
UNIBUS

DECsystem-10
DECSYSTEM-20
DIBOL
EDUSYSTEM
VAX
VMS

MASSBUS
OMNIBUS
OS/8
RSTS
RSX
IAS

CONTENTS

	Page
CHAPTER 1 INTRODUCTION	
1.1 SCOPE	1-1
1.2 GENERAL DESCRIPTION.....	1-1
1.3 BLOCK DIAGRAM	1-3
1.3.1 Drive Control.....	1-4
1.3.2 Processor.....	1-4
1.4 SPECIFICATIONS.....	1-4
1.4.1 Performance.....	1-4
1.4.2 Electrical.....	1-5
1.4.3 Mechanical.....	1-5
1.4.4 Environmental	1-5
1.5 CONFIGURATIONS	1-6
1.6 HARDWARE DOCUMENTATION ORDERING INFORMATION.....	1-7
CHAPTER 2 OPERATION	
2.1 TU58-CA RACKMOUNT CONTROLS AND INDICATORS.....	2-1
2.1.1 Front Panel.....	2-1
2.1.2 Run Indicator.....	2-1
2.1.3 Application and Removal of Power	2-1
2.2 TU58 COMPONENTS CONTROLS AND INDICATORS.....	2-2
2.2.1 Application and Removal of Power	2-2
2.3 CARTRIDGE	2-2
2.3.1 Cartridge Loading	2-2
2.3.2 Cartridge Unloading	2-3
2.3.3 Keeping Track of Cartridges.....	2-3
2.3.4 Write-Protect Tab.....	2-3
2.3.5 Cartridge Storage and Care	2-3
2.4 MAINTENANCE.....	2-4
2.4.1 Head and Puck Cleaning	2-4
2.4.2 Operator Trouble Isolation.....	2-4
2.4.3 Cartridge Wear.....	2-5
2.5 CARTRIDGE REPAIR.....	2-5
2.5.1 Metal-Base Cartridge Tape Rethreading Procedure	2-6
2.5.2 Plastic-Base Cartridge Tape Rethreading Procedure.....	2-7
2.5.2.1 Preparation for Threading	2-8
2.5.2.2 Threading the Cartridge	2-8
2.5.2.3 Closing the Cartridge.....	2-9
CHAPTER 3 PROGRAMMING	
3.1 GENERAL PRINCIPLES	3-1
3.1.1 Block Number, Byte Count, and Drive Number	3-1
3.1.2 Special Handler Functions.....	3-1

CONTENTS (Cont)

	Page
3.2	RADIAL SERIAL PROTOCOL (RSP).....3-1
3.2.1	Message Packets.....3-1
3.2.2	Flag Byte Op Codes.....3-2
3.2.3	Signal (Break) and Initialization3-2
3.3	COMMAND SET3-3
3.3.1	Command Packets.....3-3
3.3.2	Data Packets3-4
3.3.3	End Packets.....3-5
3.4	THE INSTRUCTION SET3-6
 CHAPTER 4 INSTALLATION	
4.1	INSTALLATION OF RACK VERSION.....4-1
4.1.1	Mounting in a Rack.....4-1
4.1.2	Power Selection for the Rack Version4-3
4.1.3	Removing Module From Chassis.....4-3
4.1.4	Reinstalling the Module4-5
4.2	DRIVE AND MODULE INSTALLATION (DOES NOT APPLY TO RACKMOUNT).....4-5
4.3	INTERFACE STANDARDS SELECTION AND SETUP4-5
4.3.1	Selecting Interface Standards.....4-8
4.3.2	Connecting Standards Jumpers.....4-9
4.4	OPERATIONAL CHECKOUT4-11
4.4.1	Checkout of Interface4-11
4.4.2	Checkout of RSP and Command Function4-11
 CHAPTER 5 OPTIONS	
5.1	RU \bar{N} INDICATOR.....5-1
5.1.1	Installation.....5-1
5.2	BOOT SWITCH5-2

FIGURES

Figure No.	Title	Page
1-1	Tape Cartridge Partially Inserted into Drive (Top View).....	1-2
1-2	An Exchange in Radial Serial Protocol.....	1-3
1-3	TU58 Block Diagram.....	1-3
1-4	Single Record on Tape.....	1-5
1-5	Block Locations on Tape.....	1-5

CHAPTER 1 INTRODUCTION

1.1 SCOPE

The TU58 DECTape II is a low-cost, mass-storage device which may be used in a wide variety of applications. This manual provides the information that a user needs to install, interface, and command the operation of the tape system. (For information about the operation of the TU58 under DEC operating systems, refer to the individual system manuals.)

Chapter 1 provides a general description of the TU58 and a list of its specifications including electrical and mechanical requirements. The configurations section describes the different variations of the TU58 that are available.

Chapter 2, the system operator's reference section, contains important information for day-to-day operation and routine maintenance.

Chapter 3 is the programmer's guide. It contains functional descriptions of the TU58 command set, illustrates command sequences, explains the details of the Radial Serial Protocol, and lists the system instruction codes and byte sequences.

Chapter 4 gives illustrated instructions for jumper selection; mechanical, electrical, and interface installation; and operational checkout of the tape system.

Chapter 5 has details about the optional features available in the TU58.

1.2 GENERAL DESCRIPTION

The TU58 is a random-access, fixed-length-block, mass-storage tape system. It uses preformatted tape cartridges which store 262 kilobytes of data in 512-byte blocks. There are 256 blocks on each of two tracks. They may be accessed by a program in a fashion similar to data stored on disks or DECTape, using a new, high-level instruction set. A file-oriented structure is easily implemented in an operating system by setting aside several blocks on the tape to store a directory.

The TU58 is compact and mechanically simple. The tape cartridges are DIGITAL-preformatted miniature reel-to-reel packages containing 42.7 m (140-ft) of 3.81 mm (0.150 in) wide tape. The tape is driven by a single puck which engages a roller which moves an elastomer drive belt in the cartridge. This belt loops around both tape spools and provides uniform tension and spill-free winding without mechanical linkages (Figure 1-1). The simple single-point drive mechanism allows high reliability for the entire system.

The control and drive circuitry of the TU58 is located on a single circuit board. The controller uses a microprocessor (μ P) to reduce the tape handling and communications management load on the host system.

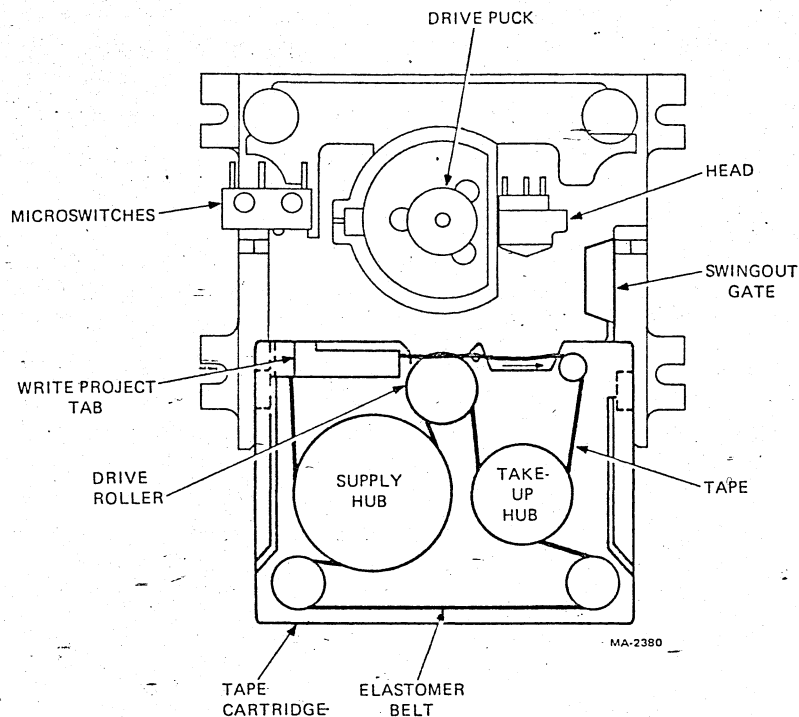

Figure 1-1 Tape Cartridge Partially Inserted into Drive (Top View)

The motor and tape head control, driver, and switching circuits to manage two tape drives are on the printed circuit board with the μP . The controller supports one or two drives, but only one drive can operate at a time. The μP controls all of the activities of the TU58. Head and motor selection, speed and direction changes, etc., are managed by outputs from I/O ports on a peripheral IC. The mechanical actions of the drives themselves are supervised by the μP to improve the system's performance.

Operational amplifiers, comparators, and logic circuits perform amplification, signal switching and conditioning, proportional control, and logic steering functions in the controller. The tape is protected by motor current limiting and an anti-runaway timer.

Because of the μP intelligence, requests from the host for data retrieval or storage need only contain simple specifications about the transfer. The controller positions the tape and performs the transfer without supervision from the host.

The host and controller communicate in a format called Radial Serial Protocol (RSP). The RSP uses two kinds of byte sequences called message packets. Both command and data packets have protocol information placed in specific locations in the byte sequence. This format is easily generated by the TU58, making host-peripheral interaction possible at a high level with low cost.

Figure 1-2 illustrates a typical RSP exchange between a host computer and the TU58. Refer to Chapter 3 for a full discussion of RSP implementation.

The serial host interface operates on full-duplex, asynchronous 4-wire lines at jumper-selectable rates from 150 to 384 kilobaud. The send and receive rates may be independently set with jumpers to operate in accordance with Electronic Industries Association (EIA) Standards RS-422 or RS-423. When set to RS-423, the TU58 is also compatible with devices complying with RS-232-C.

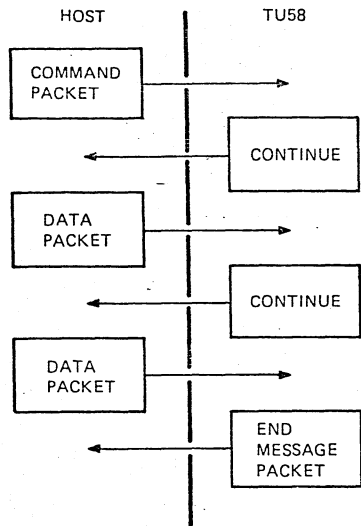

MA-2384

Figure 1-2. An Exchange in Radial Serial Protocol

1.3 BLOCK DIAGRAM

Figure 1-3 illustrates the structure of the TU58 system. The data path is along the top of the diagram, passing to the host through the processor at the right. The drive control is at the lower left, also closely associated with the processor through the I/O ports. The ports, memory, and universal asynchronous receiver-transmitter (UART) are tied to the processor by an 8-bit-wide data/address bus.

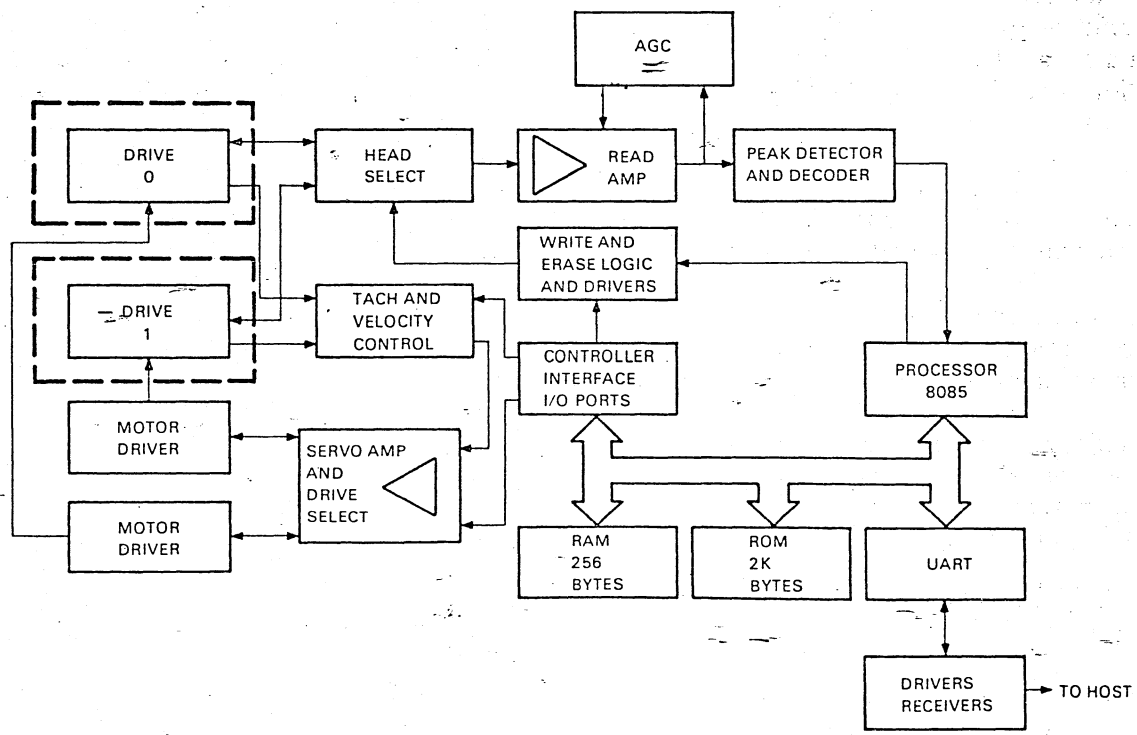

MA-2378

Figure 1-3 TU58 Block Diagram

1.3.1 Drive Control

The cartridge drive motors are powered by servo-regulated speed and direction circuits. These are controlled by the processor which monitors with tachometers and with signals from the tape. The heads are selected by processor-controlled switches and either feed the automatic-gain-controlled (AGC) read amplifier and decoder circuits or are driven by write currents encoded by the processor.

1.3.2 Processor

The processor consists of an 8085 processor supported by firmware in a 2-kilobyte read-only memory (ROM) and by scratchpad and data buffer memory in a 256-byte random access memory (RAM). The processor communicates with the drive control circuitry through a bidirectional I/O port. The UART exchanges data between the TU58 processor bus and the host computer via the serial line drivers and receivers.

1.4 SPECIFICATIONS

1.4.1 Performance

Capacity per cartridge	262,144 bytes, formatted in 512 blocks of 512 bytes each
Data transfer rate	
Read/write on tape	41.7 μ s/data bit, 24 kbytes/s
Data buffer to interface	150 to 38.4 kbaud, jumper selected
Cartridge life	5000 minimum end-to-end tape passes
Data reliability	
Soft data error rate	1 in 10^7 bits read (before self-correction)
Hard error rate	1 in 10^9 bits read (unrecoverable within 8 automatic re-tries)
Hard error rate with write-verify and system correction	2 in 10^{11} bits read/written
Error checking	Checksum with rotation
Average access time	9.3 seconds
Maximum access time	28 seconds
Read/write tape speed	76 cm/s (30 in/s)
Search tape speed	152 cm/s (60 in/s)
Bit density	315 bits/cm (800 bits/in)
Flux reversal density	945 fr/cm (2400 fr/in)
Recording method	Ratio encoding
Medium	DECTape II cartridge with 42.7 m (140 ft) of 3.81 mm (0.150 in) tape Size: 6.1 \times 8.1 \times 1.3 cm (2.4 \times 3.2 \times 0.5 in) Order TU58-K

NOTE

DECTape II is a preformatted version of the 3M DC100A or equivalent.

Track format (Figures 1-4 and 1-5)

Two tracks, each containing 1024 individually numbered, firmware-interleaved "records." Firmware manipulates 4 records at each operation to form 512-byte blocks.

Drive

Single motor, head integrally cast into molded chassis

Drives per controller

1 or 2. Only one may operate at a time.

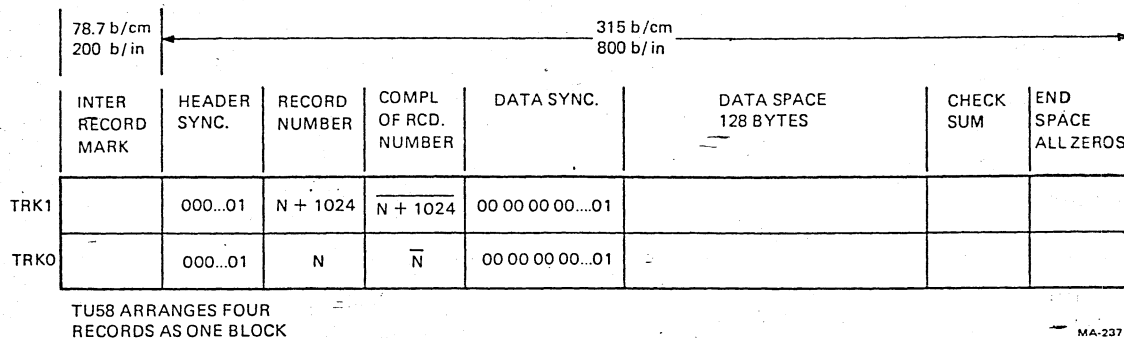

Figure 1-4 Single Record on Tape

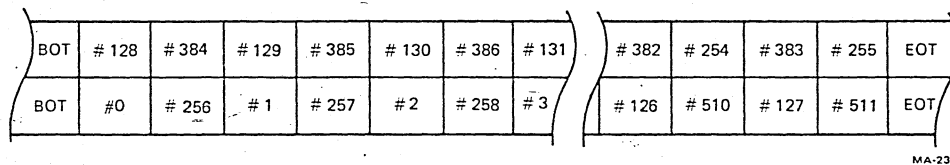

Figure 1-5 Block Locations on Tape

1.4.2 Electrical

Power consumption

Module and 1 or 2 drives

11 W, typical, drive running
 +5 V, $\pm 5\%$ at 0.75 A, maximum
 +12 V +10% -5% at 1.2 A, peak
 0.6 A average running
 0.1 A idle

These voltages need not stabilize simultaneously upon power-on.

Rackmount

90-128, 180-256 Vac, 47-63 Hz, 35 W maximum

Serial interface standards

In accordance with RS-422 or RS-423; compatible with RS-232-C

1.4.3 Mechanical

Drive

8.1 H \times 8.3 D \times 10.6 W cm (3.2 \times 3.3 \times 4.1 in) with 19 cm (7.5 in) cable

Board (Module)

13.2 H \times 26.5 D \times 3.5 W cm (5.19 \times 10.44 \times 1.4 in)

Rackmount cabinet

13.2 H \times 38.1 D \times 48.3 W cm (5.19 \times 15.0 \times 19.0 in)

Power connector to module

AMP 87159-6 with 87027-3 contacts (DEC part nos. 12-12202-09, 12-12203-00)

Power connector to rackmount

European IEC standard

Interface connector to module

AMP 87133-5 with 87124-1 locking clip contacts and 87179-1 index pin (DEC part nos. 12-14268-02, 12-14267-00, 12-15418-00)

1.4.4 Environmental

The TU58 meets the following environmental specifications. When the TU58-AB or -BB (Paragraph 1.5) is integrated in a host device such as a terminal, convection provides adequate cooling if the interior temperature is below 50° C (122° F) dry bulb, 26° C (79° F) wet bulb.

Maximum dissipation

TU58-CA	120 Btu/hour
TU58-AB, TU58-BB	34 Btu/hour

Temperature

TU58-CA operating	15° C (59° F) to 32° C (90° F) ambient
TU58-CA nonoperating	-34° C (-30° F) to 60° C (140° F)
Medium operating temperature	0° C (32° F) to 50° C (122° F)
Maximum temperature difference between system ambient and TU58 module	18° C (32.4° F)

Relative Humidity, non-condensing

TU58 operating	
Maximum wet bulb	26° C (79° F)
Minimum dew point	2° C (36° F)
Relative humidity	20% to 80%
TU58 nonoperating	5% to 98%
Medium nonoperating	10% to 80%

CAUTION

If a cartridge has been exposed to either the maximum or minimum temperature extreme, the tape should be rewound one complete cycle before using (Paragraph 2.3.5). This is done to bring the tape to the proper tension.

1.5 CONFIGURATIONS

The TU58 is available in the following configurations with accompanying designations.

Components

TU58-AB	Serial interface controller module, surface mounting, with one drive.
TU58-BB	Serial interface controller module, surface mounting, with two drives.

Subsystems

TU58-CA	Rackmount, two drives, serial interface controller module, power supply 110/220 V switch-selectable, detachable line cord and fuses for 110 V, two cartridges.
---------	--

NOTE

Order interface cable separately.

Additional Supplies

BC20Y-25 interface cable TU58 to DL-11 and DLV-11, 7.5 m (25 ft) (10-pin-to-40-pin connector)
BC20Z-25 interface cable TU58 to DLV-11J, 7.5 m (25 ft) (10-pin-to-10-pin connector)
TU58-K preformatted tape cartridges. Available singly or in packs of five.
TUC-01 Tape Drive Cleaning Kit

1.6 HARDWARE DOCUMENTATION ORDERING INFORMATION

The following TU58 DECTape II Tape Subsystem hardware manuals can be purchased from DIGITAL's Accessory and Supplies Group.

Part No.	Title
EK-0TU58-UG-001	TU58 Tape Subsystem User's Guide (paper)
EK-0TU58-PS-001	TU58 Tape Subsystem Pocket Service Guide (card)
EK-0TU58-TM-001	TU58 Tape Subsystem Technical Manual (microfiche)

All purchase orders for hardware manuals should be forwarded to:

Digital Equipment Corporation
Cotton Road
Nashua, New Hampshire 03060
Accessory and Supplies Group (P086)

Purchase orders must show shipping and billing addresses and state whether a partial shipment will be accepted. All correspondence and invoicing inquiries should be directed to the above address or call toll-free 1-800-258-1710 in the continental U.S. only.

CHAPTER 2 OPERATION

2.1 TU58-CA RACKMOUNT CONTROLS AND INDICATORS

2.1.1 Front Panel

The front panel (Figure 2-1) has two slots for the tape cartridges and two tape motion indicator lights for the drives. In addition, the decorative bezel has a small compartment that can be used to store up to six cartridges in their boxes.

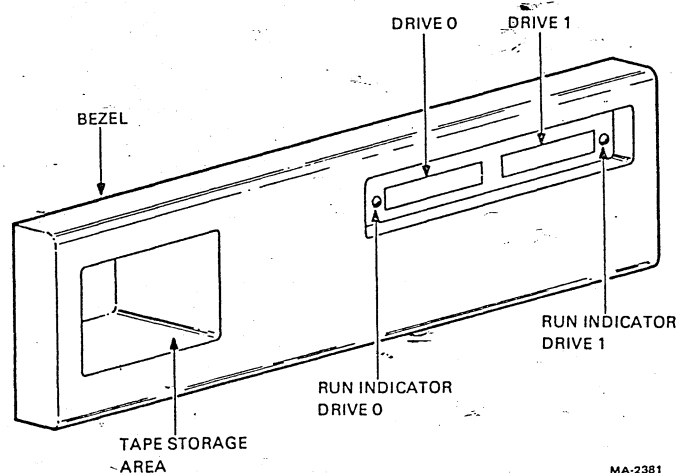

Figure 2-1 TU58-CA Rackmount Front Panel

2.1.2 Run Indicator

Each tape drive has an LED that lights to indicate tape motion. Since data loss can occur if a cartridge is removed while the tape is being written, the cartridge should not be removed if the light is on.

2.1.3 Application and Removal of Power

The TU58-CA does not have a power switch. If an outlet is available on a system power controller, the TU58 may be plugged into the controller. Otherwise, it does not need to be turned off. Its idling power consumption is less than 20 W.

When power is applied, the TU58 initializes itself, performs its internal diagnostic tests, and then asks the host for an acknowledgement before it settles down to wait for instructions. Refer to Paragraph 3.2.3 for a description of the required exchange.

If power is removed while a tape is being written, data may be lost. There are no other restrictions on power removal.

2.2 TU58 COMPONENTS CONTROLS AND INDICATORS

Refer to the options section (Chapter 5) for installation and operation of OEM features.

2.2.1 Application and Removal of Power

The TU58 may be supplied with power from a host system. It is ready for operation within 1 second of voltage stabilization. It does not need to be turned off when not in use; its idling power consumption is less than 5 W.

When power is applied, the TU58 initializes itself, performs its internal diagnostic tests, and then asks the host for an acknowledgement before it settles down to wait for instructions. Refer to Paragraph 3.2.3 for a description of the required exchange.

If power is removed while a tape is being written, data may be lost. There are no other restrictions on power removal.

2.3 CARTRIDGE

2.3.1 Cartridge Loading

The TU58 drive is designed to make correct loading easy. To load the cartridge, hold it label-up, line it up with the grooves in the chassis, and slide it in with a firm push. Figure 2-2 illustrates the fit of the cartridge into the drive chassis grooves.

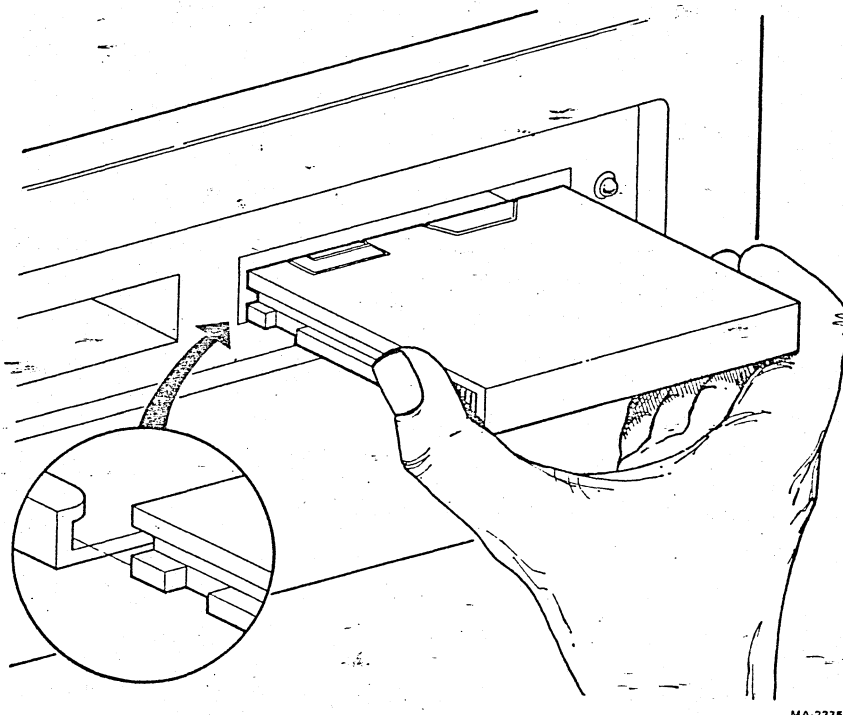

Figure 2-2 Loading a Cartridge

2.3.2 Cartridge Unloading

Unloading the cartridge is as simple as loading. Just pull it straight out. It is best to wait for the tape to stop, as indicated by the run light, before removing the cartridge. The mechanism cannot be damaged by removing the cartridge while the tape is moving, but if a write is in progress, data may be lost. An error message will be sent to the host if a command is interrupted by removal of a cartridge. Cartridges should be removed from the drives when the system is not being used to prevent formation of flat spots on the motor puck.

2.3.3 Keeping Track of Cartridges

In non-file-structured systems, the cartridge does not have an identifying number or label recorded on the tape. If a cartridge is changed during a session, the TU58 will not know that a different cartridge was loaded; the operator must keep track of the contents of various cartridges.

2.3.4 Write Protect Tab

Each tape cartridge has a movable tab which, when properly positioned, protects data on the tape from unintended write operations. When this Write Protect tab (Figure 2-3) is in the inner position (toward the drive roller), it locks out the write circuitry.

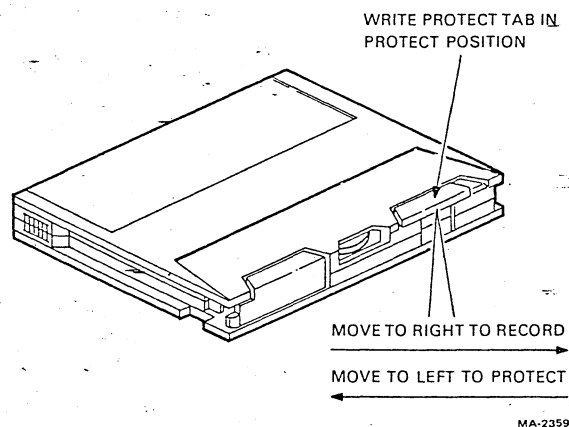

Figure 2-3 Write Protect Tab

When the Write Protect tab is in the outer position, it closes a switch in the chassis and allows the controller to write when it is commanded to. The operator should be sure that system or program tapes are backed up with copies before loading them into the TU58 with their Write Protect tabs set to record.

The Write Protect tab can be completely removed for long-term write protection. On the metal-base cartridge, lift the protect tab with a fingernail under the protruding end. Replace it by dropping it into its slot and pressing on it until it snaps. On the plastic-base cartridge, pry up the tab from its back edge partway and then lift from the front. To replace it, drop it into its slot and press forward and down.

2.3.5 Cartridge Storage and Care

Store cartridges in their cases, away from dust and heat or direct sunlight. Do not touch the tape; there is no safe way to clean the tape and permanent errors may result. Keep tools and other ferrous or magnetic objects away. If a tape is suspected of having been exposed to environmental extremes as listed in the specifications and if the software operating system permits, wind it all the way through with a "Newtape" (Paragraph 3.1.2) or equivalent command or by requesting positionings to blocks at each end of the tape before attempting to store data on the cartridge.

2.4 MAINTENANCE

2.4.1 Head and Puck Cleaning

After 250 hours of tape running time or semi-annually, clean the head and motor puck with a long-handled cotton applicator moistened with DEC cleaning fluid (from cleaning kit TUC-01), 95 percent isopropyl alcohol, fluorocarbon TF, 113 or equivalent (Figure 2-4). Push the puck around with the applicator to clean its entire surface. Regular cleaning minimizes tape and head wear and prevents tape damage and data errors caused by contamination. This is the only regular maintenance required by the TU58.

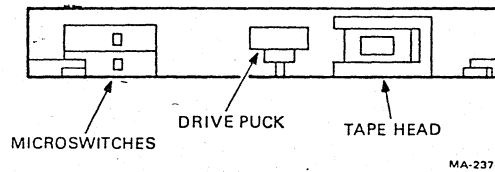

Figure 2-4 View Into Tape Drive Cartridge Slot

2.4.2 Operator Trouble Isolation

Table 2-1 lists potential problems and possible corrective actions and comments. (Some items are not applicable to components.)

Table 2-1 Operator Trouble Isolation

Symptom	Action/Comments
TU58 does not respond to host.	<ol style="list-style-type: none"> 1. Ensure that the TU58-CA is plugged into a live ac socket (or proper dc source for components). 2. Check that the voltage selection switch is properly set. 3. Ensure that the fuse and power cord are intact and properly inserted. 4. Check that the baud rates and interface standards are the same for both the TU58 and the host interface board (Paragraph 4.3). 5. If possible, observe the self-test indicator light on the controller module. [Remove the bezel on the rack-mount version (Paragraph 4.1.1)]. When power is applied, the light should shine for half a second, go out for another half second, and then relight. This means the controller has passed its automatic self-test and is ready for operation. If the light remains off, there is some problem within the module or in the interface. Check that the interface cable is intact and properly inserted. If the serial interface is suspected and the standards are correct, try a new interface cable. An open wire in the line from the host prevents the light from coming on. Other causes require servicing.
TU58 does not write (reads okay).	<ol style="list-style-type: none"> 1. Check that the Write Permit tab is correctly on the cartridge (Figure 2-3). 2. The trouble may be in a drive. Try writing on the other drive. Any problem except the Write Permit tab setting requires service.

Table 2-1 Operator Trouble Isolation (Cont)

Symptom	Action/Comments
Read errors (Some host operating systems may provide this or a similar message.)	<ol style="list-style-type: none"> 1. Clean the head. Dirt and tape oxide buildup can cause errors (Paragraph 2.4.3). 2. The tape may contain errors that were written onto it. If a tape is in poor condition or if data is not verified at write-time, errors may become a permanent part of the recording.
TU58 sends motor-stopped error messages.	This indicates that a malfunction has occurred in the data recovery section and the runaway timer has stopped the motor. The TU58 should not be commanded to move tape more than twice under these conditions without checking the cartridge. Make sure that the tape is not getting near the end where it might come free of the hub.

2.4.3 Cartridge Wear

Cartridge tape is expected to last for 5000 end-to-end-and-back-passes. If a cartridge is at the end of its life, a read operation may require several retries to get the data in the presence of soft errors. A soft error is a temporary data loss which is usually caused by a speck of dirt or oxide on the tape or head surface. This speck lifts the tape away from head and causes signal loss and consequent read errors. A few extra passes of the tape past the head may knock the speck away and allow error-free reading. If it happens often, the tape is probably old and shedding oxide and should be copied and discarded as soon as possible.

2.5 CARTRIDGE REPAIR

Under unusual circumstances of controller failure or cartridge mishandling, the tape might come free of the hub. The tape is not fastened to the hub but is held in place by the elastomer belt and by the tape's wrap around itself. The procedures for looping the tape back onto the hub help the user prevent important data loss, do not substitute for the customary precautions of proper handling and backup copying. Two procedures are given here. One is for the metal-base cartridge and the other is for the plastic-base cartridge.

These are moderately difficult procedures requiring the use of small tools. Minimum tools are a no. 1 Phillips head screwdriver and a small probe (a straightened paper clip can be used) for the metal-base cartridge and a 5 mm (3/16 in) flat blade screwdriver and probe for the plastic-base cartridge. Tweezers are helpful.

NOTE

Keep magnetized tools away from the bulk of the tape and do not touch the tape surface except at the ends because fingerprints cause errors. (If staples or paper clips stick to a tool, it is magnetized.)

2.5.1 Metal-Base Cartridge Tape Rethreading Procedure

1. Open the cartridge by removing the four baseplate Phillips head screws (Figure 2-5) and set it upright on the work surface with the cover still on.
2. Lift the cover off.

NOTE

To remove the head gate, swing it out to clear the tape before lifting it up. Its replacement is optional.

3. Thread the end of the tape around the tape guides (Figure 2-6).
4. Moisten the end of the tape with water to get it to stick to the hub.
5. With a small amount of slack at the free end, insert the end between the hub and belt and operate the drive roller with a finger to take up the tape. As soon as the tape is grabbed, keep some back tension on the tape. This will keep it feeding straight into the hub.
6. Continue to wind. Watch for the loose end as it comes around. If it separates from the hub, tuck it under the next turn of tape with the probe. (Back up if the end is too long.)
7. Continue to wind a few more turns with the drive roller while applying tension to the tape.
8. Hold the takeup hub and drive roller fixed, and rotate the supply reel to take up the slack.
9. Continue winding the tape about 20 turns before reassembling.
10. To reassemble the cartridge, reinstall the gate (if desired) by aligning the long and short ends of the spring with the long and short ends of the gate, as in Figure 2-7.
11. Drop the spring into the well in the gate. Holding the spring down with a thumbnail or probe, rotate the long end of the spring around to the slot that is at a right angle to the long dimension of the gate. Push the end of the spring into the slot; it should stay there by itself.

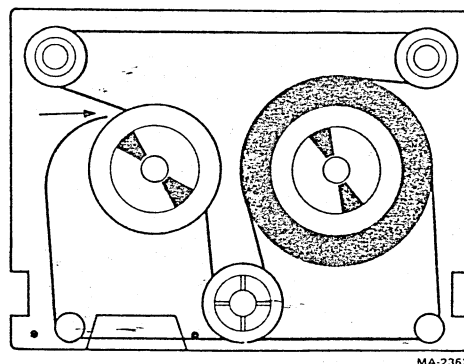
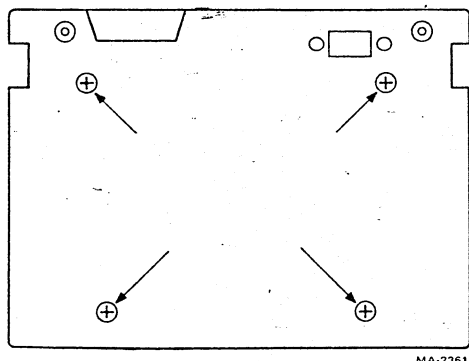

Figure 2-5 Metal Baseplate Screw Locations

Figure 2-6 Threading the Metal-Base Cartridge

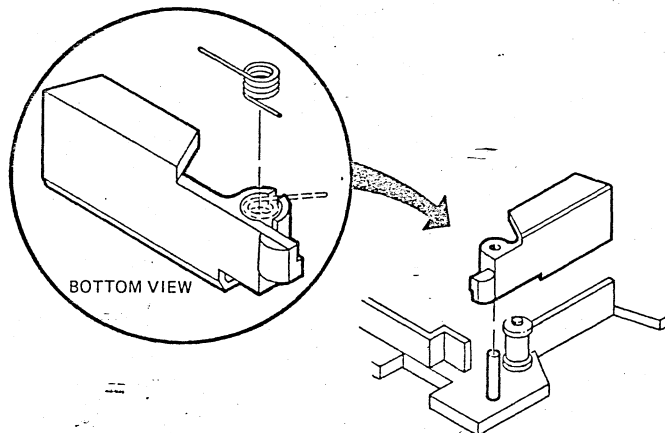

Figure 2-7 Head Gate and Spring

12. Hold the gate halfway out so that the gate and the spring end do not touch the tape. Slowly press the gate down onto its pin on the cartridge baseplate. Reach in with the probe and press the spring down. It will clear its holding slot and snap into position, closing the gate.
13. Carefully lower the cartridge cover into place and reinstall the screws.

2.5.2 Plastic-Base Cartridge Tape Rethreading Procedure

Open the plastic-base cartridge case by prying the sides apart with a screwdriver (Figure 2-8).

Do not cut the label on the back of the cartridge; it acts as a hinge to help hold the case together. The leverage applied when spreading the case halves will break the rear welds (Figure 2-9).

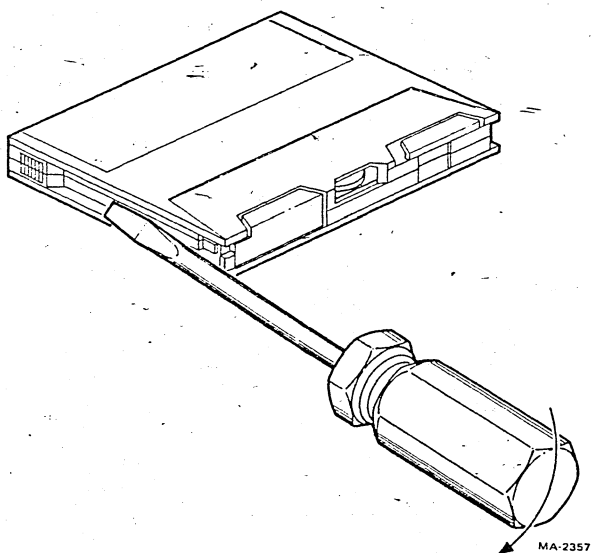

Figure 2-8 Open the Plastic-Base Cartridge

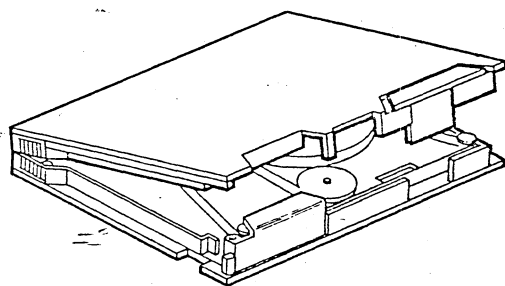

Figure 2-9 Welded Case Halves Separated

2.5.2.1 Preparation for Threading – The four rollers and tape hubs in the plastic-base cartridge are held in their operating plane by the top and bottom of the case together. When the top is off, the various parts tend to creep out of position, and the elastomer belt can get folded under the hubs.

1. To organize the parts for threading, remove and discard the head gate and spring. Take the empty tape hub from the case and set it aside.
2. Remove the floating roller (Figure 2-10).
3. Rearrange the elastomer belt around the drive roller and the full hub.
4. Reinstall the floating roller and use it to stretch the belt tight.
5. Put the empty tape hub on its pin.
6. Using some fingers to hold the floating roller and belt and other fingers to push the hub down, use a straightened paper clip or pencil to guide the elastomer belt around the hub. The hub should seat against the base with the belt around it.

2.5.2.2 Threading the Cartridge

1. Pull several centimeters (a few inches) of tape off the supply hub and through the tape guides (Figure 2-11).

NOTE

Hold all parts down when moving them. Otherwise, the hubs will creep up the pins and cause the belt to slip. Then the procedure must be restarted at Paragraph 2.5.2.1.

2. Moisten the end of the tape with water to get it to stick to the hub.
3. With a small amount of slack at the free end, insert the end between the hub and belt, and operate the floating roller to take up the tape.

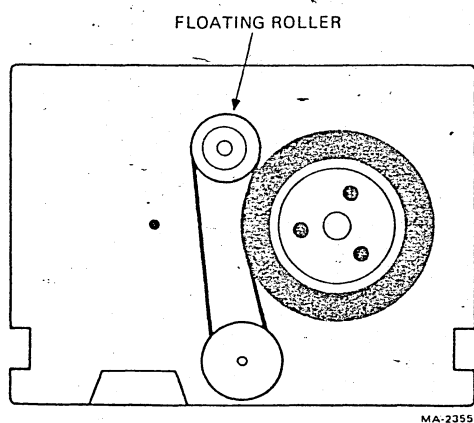

MA-2355

Figure 2-10 Stretch the Belt with the Floating Roller

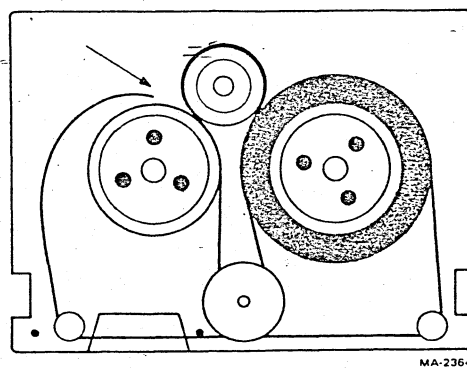

MA-2364

Figure 2-11 Threading the Plastic-Base Cartridge

4. As soon as the tape is grabbed, keep some back tension on the tape. This keeps the tape feeding straight into the hub.
5. Continue to wind. Watch for the loose end as it comes around. If it separates from the hub, tuck it under the next turn of tape with the paper clip. (Back up if the end is too long.)
6. Continue to wind a few more turns with the floating roller while applying tension to the tape.
7. Now hold the takeup hub, drive, and floating rollers fixed and rotate the supply hub to take up the slack.

2.5.2.3 Closing the Cartridge - The case should fold closed on its label hinge. Do not reinstall the head gate. The mirror window may need to be pressed in slightly to clear the bottom. Make sure that the case is completely closed around the front.

A piece of adhesive tape around the case at the mirror window will keep it securely closed when combined with the label at the back. (The mirror is not used.)

Now use a finger to operate the drive roller and wind the tape about 20 turns onto the takeup hub before inserting the cartridge into a drive.

NOTE

The only reason for performing this exercise is to copy the data from the injured tape as soon as possible. Discard the cartridge after copying.

CHAPTER 3 PROGRAMMING

3.1 GENERAL PRINCIPLES

The TU58 is controlled by a high-level command set that unburdens the host computer from device-related operations such as tape positioning and read retries. The TU58 firmware contains subroutines that are activated by brief strings of command bytes. The command strings contain the numerical code for the operation to be performed and the location and size of data files that are to be transferred, when applicable. They also contain various housekeeping characters that are part of the Radial Serial Protocol (RSP) under which the byte sequences are defined. The byte sequences are called message packets and are designed to be suitable for transmission by asynchronous interfaces.

3.1.1 Block Number, Byte Count, and Drive Number

The TU58 uses the block number and byte count to write or retrieve data. If all of the desired data is contained within a single 512-byte block, the byte count will be 512 or less. When the host asks for a particular block and a 512-or-less byte count, the TU58 will position the specified drive (unit) at that block and transfer the number of bytes specified. If the host asks for a block and also a byte count greater than that of the 512-byte boundary, the TU58 will read as many sequential blocks as are needed to fulfill the byte count. The same process applies to the write function. This means that the host software or an on-tape file directory need only store the number of the first block in a file and the file's byte count to read or write all the data without having to know the additional block numbers.

3.1.2 Special Handler Functions

Some device-related functions are not dealt with directly in the RSP or in the TU58 firmware.

1. A short routine (perhaps entitled "Newtape") should be included in a TU58 handler to provide a complete wind-rewind for new or environmentally stressed tape cartridges. This procedure brings the tape pack to proper operating tension levels.
2. A TU58 handler should check the success code (byte 3 of the RSP end message) for the presence of soft errors. This enables action to be taken before hard errors (permanent data losses) occur. For example, if the number of retries on a particular cartridge reaches some value, a message like "Tape Maintenance Required" is presented to the operator. This suggests that prompt copying of the tape and cleaning of the head is in order.

3.2 RADIAL SERIAL PROTOCOL (RSP)

3.2.1 Message Packets

All communication between the TU58 and the host is divided into message packets, which are groups of bytes arranged in fixed order. Position within the packet determines the meaning of each byte. There are three kinds of message packets: command, data, and end messages. The end message is a special case of the command packet. In addition, there are three single-byte protocol management messages: INIT, Continue, and XOFF.

Each packet begins with a flag byte, which announces its contents. The next byte in a message packet is the byte count. This is the number of message characters in the packet, excluding the flag, byte count, and checksum. Up to 128 message bytes may be in each packet. Larger blocks of data are sent with multiple packets. The last two bytes of the message packet are a 16-bit checksum. The checksum is formed by summing successive byte pairs taken as 16-bit words and using an end-around carry from bit 15 to bit 0. The flag and byte count are included in the checksum.

3.2.2 Flag Byte Op Codes

Bits 7-5 of the op code are reserved.

00001	Data
00010	Control (command)
00100	INIT
10000	Continue
10011	XOFF

Data	This flag informs the receiver that data rather than commands are arriving. The receiver loads the incoming bytes into a buffer area in memory. It does not look for an op code to execute.
Command	The command flag informs the TU58 that a command packet follows. An instruction code will be in this packet. The flag is particularly important when the TU58 encounters an error condition. In this case, it sends an end packet before data transfer is complete. The host knows that the end packet has been sent because the packet received has a command flag instead of a data flag.
INIT	This op code is sent from the host to the TU58 to cause it to execute its power-up sequence. The TU58 returns Continue after completion. It is sent from the TU58 to the host to indicate that the power-up sequence has occurred. When the TU58 makes a protocol error or receives an invalid command, it reinitializes and sends INIT to the host. The TU58 must send up to 261 INITs in this case because the host may think it is receiving a message packet and will not interpret the INIT until the message packet is complete.
Continue	After a message is sent from host to the TU58, the host must wait until the TU58 sends Continue before any more messages can be sent. This permits the TU58 to control the flow of data.
XOFF	Ordinarily, the TU58 does not have to wait between messages to the host. However, if the host is unable to receive all of a message from the peripheral at once, it may send XOFF. The TU58 stops transmitting immediately and waits until the host sends Continue to complete the transfer when it is ready. (Two characters may be sent by the UART to the host after the TU58 receives XOFF.)

3.2.3 Signal (Break) and Initialization

Signal is defined in the RSP specification as a unique logic entity that can be interpreted as signal regardless of the state of the protocol. Its implementation for the TU58 is the break condition on the serial line. Break is transmitted when the serial line is kept in the "space" condition for more than one character time. This causes the TU58's UART to set its framing error bit. The TU58 will interpret the framing error as break.

Break has two applications in the TU58: one is routinely used, and the other is for special conditions. When the TU58 is powered up, it performs its internal checkout and initialization and then transmits INITs continuously to the host to inform the host that it is present. The host acknowledges the TU58 by sending break for a minimum of one character time, and then sending two INITs. The TU58 responds with Continue and enters an idle state in which it will wait for further instructions.

If communications break down, due to any transient problem, the host may restore order by sending break and INIT as outlined above. Whatever faulty operations were underway will be cancelled, and the TU58 will reinitialize itself, return Continue, and wait for instructions.

With DEC serial interfaces, the initialize sequence may be sent by the following sequence of operations. Set the break bit in the transmit control status register, then send two null characters. When the transmit ready flag is set again, remove the break bit. This will time Break to be one character time long. The second character will be discarded by the TU58 controller. Next, send two INIT characters. The first will be discarded by the TU58. The TU58 will respond to the second INIT by sending Continue. When Continue has been received, the initialize sequence is complete and any command packet may follow.

3.3 COMMAND SET

The command set for the TU58 provides the capabilities required for the performance of random-access operations. To allow for future development, certain op codes in the command set have been reserved; these commands have unpredictable results and should not be used. Op codes not listed in the command set are illegal and result in the return of an end packet with the "bad op code" success code.

A data transfer operation uses three or more message packets. The first packet is the command packet from host to the TU58. Next, the data is transferred in 128-byte packets in either direction (as required by read or write). After all data is transferred, the TU58 sends an end packet. If the TU58 encounters a failure before all data has been transferred, it sends the end packet as soon as the failure occurs.

3.3.1 Command Packets

The command packet format is shown in Table 3-1. Bytes 0, 1, 12, and 13 are the message delivery bytes. Their definitions are as follows.

0	Flag	This byte is set to 00000010 to indicate that the packet is a Command packet.
1	Message Byte Count	Number of bytes in the packet excluding the four message delivery bytes. This is decimal 10 for all command packets.
12, 13	Checksum	The 16-bit checksum of bytes 0 through 11. The checksum is formed by treating each pair of bytes as a word and summing words with end around carry.

Table 3-1 Command Packet Structure

Byte	Byte Contents
0	Flag = 0000 0010
1	Message Byte Count = 0000 1010
2	Op Code
3	Modifier
4	Unit Number
5	Switches
6	Sequence Number - Low
7	Sequence Number - High
8	Byte Count - Low
9	Byte Count - High
10	Block Number - Low
11	Block Number - High
12	Checksum - Low
13	Checksum - High

The remaining bytes are defined as follows.

2	Op Code	Operation being commanded. Refer to Table 3-2 and Paragraph 3.4 for definitions.
3	Modifier	Permits variations of commands.
4	Unit Number	Selects drive 0 or 1.
5	Switches	Always zero for TU58.
6, 7	Sequence Number	Always zero for TU58.
8, 9	Byte Count	Number of bytes to be transferred by a read or write command. Ignored by other commands.
10, 11	Block Number	The block number to be used by commands requiring tape positioning.

Table 3-2 Instruction Set

Op Code	Instruction
0	NOP
1	INIT
2	Read
3	Write
4	(Reserved)
5	Position
6	(Reserved)
7	Diagnose
8	Get Status
9	Set Status
10	(Reserved)
11	(Reserved)

3.3.2 Data Packets

The data packet is shown in Table 3-3. The flag byte is set to 00000001. The number of data bytes may be between 1 and 128 bytes. For data transfers larger than 128 bytes, the transaction is broken up and sent 128 bytes at a time. The host is assumed to have enough buffer capacity to accept the entire transaction, whereas the TU58 only has 128 bytes of buffer space. For write commands, the host must wait between message packets for the TU58 to send the continue flag (00010000) before sending the next packet. Since the host has enough buffer space, the TU58 does not wait for a continue flag between message packets when it sends back read data.

Table 3-3 Data Packets

Byte	Byte Contents
0	Flag = 0000 0001
1	Byte Count = M
2	First Data Byte
3	Data
.	.
.	.
M	Data
M+1	Last Data Byte
M+2	Checksum L
M+3	Checksum H

3.3.3 End Packets

The end packet is sent to the host by the TU58 after completion or termination of an operation or on an error. The end packet is shown in Table 3-4. The definition of bytes 0, 1, 12, and 13 are the same as for the command packet. The remaining bytes are defined as follows.

Byte 2	Op Code - 0100 0000 for end packet
Byte 3	Success Code 0 = Normal Success 1 = Success but with Retries -1 = Failed Self-Test -2 = Partial Operation (End of Medium) -8 = Bad Unit Number -9 = No Cartridge -11 = Write Protected -17 = Data Check Error -32 = Seek Error (Block Not Found) -33 = Motor Stopped -48 = Bad Op Code -55 = Bad Record Number <i>-6 = hard read error.</i>
Byte 4	Unit Number 0 or 1 for Drive Number
Byte 5	Always 0
Bytes 6, 7	Sequence Number - Always 0 as in command packet
Bytes 8, 9	Actual Byte Count - Number of bytes handled in transaction. In a good operation, this will be the same as the data byte count in the command packet.
Bytes 10, 11	Summary Status

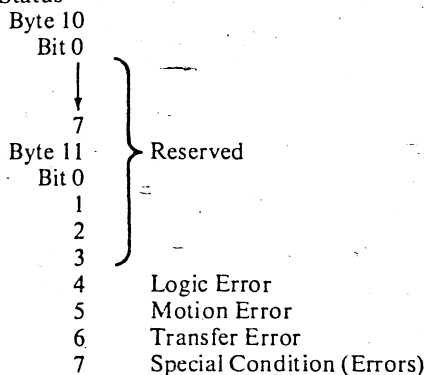

Table 3-4 End Packet

Byte	Byte Contents
0	Flag = 0000 0010
1	Byte Count = 0000 1010
2	Op Code = 0100 0000
3	Success Code
4	Unit
5	Not Used
6	Sequence No. L
7	Sequence No. H
8	Actual Byte Count L
9	Actual Byte Count H
10	Summary Status L
11	Summary Status H
12	Checksum L
13	Checksum H

3.4 THE INSTRUCTION SET

The instructions and their op codes are shown in Table 3-2. The following is a brief description and usage example of each.

OP CODE 0 NOP

This instruction causes the TU58 to return an end packet. There are no modifiers to NOP. The NOP packet is shown below.

BYTE				
0	0000	0010	FLAG	
1	0000	1010	MESSAGE BYTE CNT	
2	0000	0000	OP CODE	
3	0000	0000	MODIFIER	
4	0000	000X	UNIT NUMBER (IGNORED)	
5	0000	0000	SWITCHES (NOT USED)	
6	0000	0000	SEQ NO.	
7	0000	0000	SEQ NO.	NOT USED
8	0000	0000	BYTE COUNT L	NO DATA INVOLVED
9	0000	0000	BYTE COUNT H	INVOLVED
10	0000	0000	BLOCK NO. L	NO TAPE POSITION
11	0000	0000	BLOCK NO. H	
12	0000	101X	CHECKSUM L	
13	0000	1010	CHECKSUM H	

The TU58 returns the following end packet.

0	0000	0010	FLAG	
1	0000	1010	MESSAGE BYTE CNT	
2	0100	0000	OP CODE	
3	0000	0000	SUCCESS CODE	
4	0000	000X	UNIT (IGNORED)	
5	0000	0000	NOT USED	
6	0000	0000	SEQ. L	
7	0000	0000	SEQ. H	NOT USED
8	0000	0000	ACTUAL BYTE CNT L	NO DATA INVOLVED
9	0000	0000	ACTUAL BYTE CNT H	INVOLVED
10	0000	0000	SUMMARY STATUS L	
11	XXXX	XXXX	SUMMARY STATUS H	
12	000X	XXXX	CHECKSUM L	
13	XXXX	XXXX	CHECKSUM H	

OP CODE 1 INIT

This instruction causes the TU58 controller to reset itself to a ready state. No tape positioning results from this operation. The command packet is the same as for NOP except for the op code and the resultant change to the low order checksum byte. The TU58 sends the same end packet as for NOP after reinitializing itself. There are no modifiers to INIT.

OP CODE 2 Read, and Read with Increased Threshold

This instruction causes the TU58 to position the tape in the drive selected by Unit No. to the block designated by the block number bytes. It reads data starting at the designated block and continues reading until the byte count (command bytes 8 and 9) is satisfied. After data has been sent, the TU58 sends an end packet. Byte 3 indicates success, success with retries, or failure of the operation. In the event of failure, the end packet is sent at the time of failure without filling up the data count. The end packet will be recognized by the host by the flag byte. The host will see a command flag (0000 0010) instead of a data flag (0000 0001).

There is one modifier to the read command. A modifier of 0000 0001 causes the TU58 to read the tape with an increased threshold in the data recovery circuit. This makes the tape drop bits if any weak spots are present. Thus, if the TU58 can read error-free in this mode, the data is healthy. The read transaction between TU58 and host is shown in Figure 3-1.

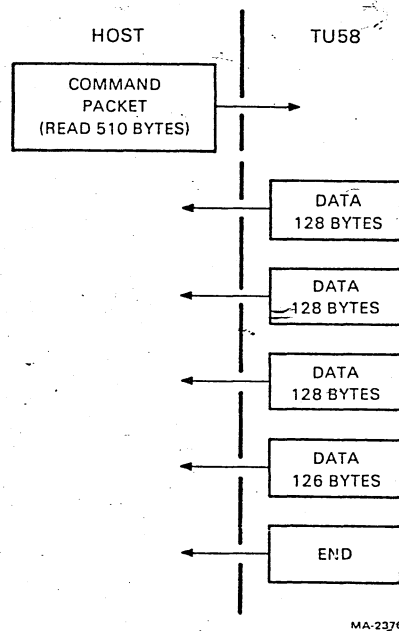

Figure 3-1 Read Command Packet Exchange

OP CODE 3 Write, and Write and Read Verify

This op code causes the TU58 to position the tape in the selected drive to the block specified by the number in bytes 10, 11 of the command packet and write data from the first data packet into that block. It writes data from subsequent data packets into one or more blocks until the byte count called out in bytes 8, 9 of the command packet has been satisfied.

The controller automatically zero-fills any remaining bytes in an 512-byte tape block.

There is one modifier permitted with the write command. A modifier of 0000 0001 causes the TU58 to write all of the data and then back up and read the data just written with increased threshold and test the checksum of each record. If all of the checksums are correct, the TU58 sends an end packet with the success code set to 0 (or 1 if retries were necessary to read the data). Failure to read correct data results in a success code of -6 (1111 1010) to indicate a hard read error.

The write operation has to cope with the fact that the TU58 only has 128 bytes of buffer space. It is necessary for the host to send a data packet and wait for the TU58 to write it before sending the next data packet. This is accomplished using the continue flag. The continue flag is a single byte response of 0001 0000 from TU58 to host. The write operation is shown for both write and write/verify operations in Figure 3-2.

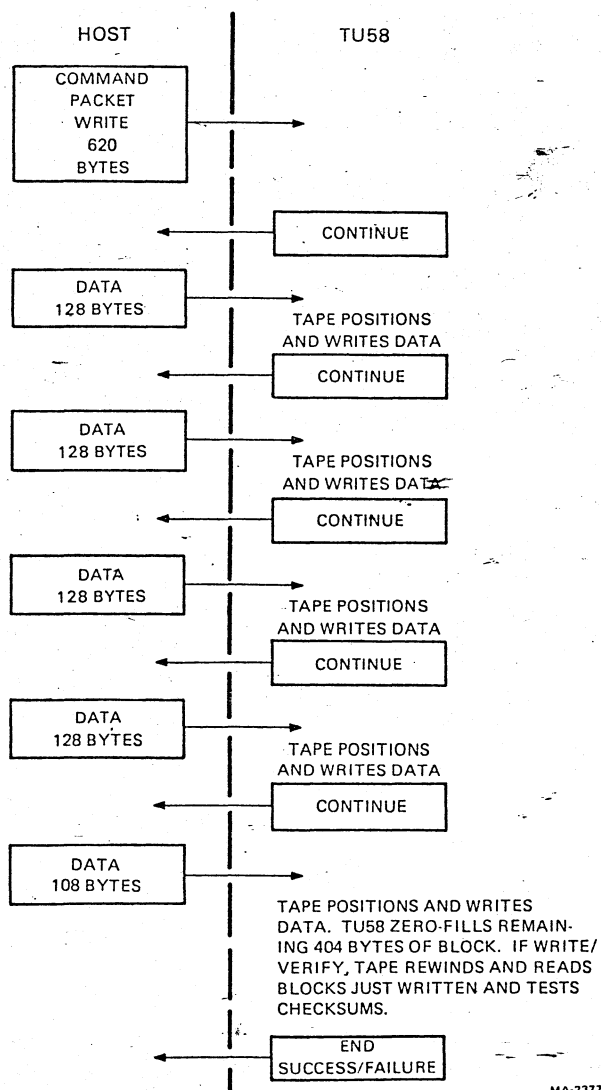

Figure 3-2 Write Command Packet Exchange

OP CODE 4 (Reserved)

OP CODE 5 Position

This command causes the TU58 to position tape on the selected drive to the block designated by bytes 10, 11. After reaching the selected block, it sends an end packet. No modifiers are used.

OP CODE 6 (Reserved)

OP CODE 7 Diagnose

This command causes the TU58 to run its internal diagnostic program which tests the processor, ROM, and RAM. Upon completion, TU58 sends an end packet with appropriate success code (0 = Pass, -1 = Fail).

OP CODE 8 Get Status

This command is treated as an NOP. The TU58 returns an end packet.

OP CODE 9 Set Status

This command is treated as an NOP. The TU58 returns an end packet.

OP CODE 10 (Reserved)

OP CODE 11 (Reserved)

CHAPTER 4 INSTALLATION

4.1 INSTALLATION OF RACK VERSION

4.1.1 Mounting in a Rack

The TU58-CA rackmount unit mounts in 13.2 cm (5.2 in) of standard 48.3 cm (19 in) width rack. It should be located so that the 2 m (6 ft) power cord can reach a power controller outlet box such as the DEC 861 or any power outlet.

To get to the mounting holes, remove the bezel (Figure 4-1) by gripping it at the top and bottom with both hands. Rotate it out from the bottom and lift it away. (If the unit is installed in a recessed rack, the bezel may be removed by gripping it with both hands on the left edge with fingers or thumbs inside the storage well. Pull sharply out and swing the bezel away.

WARNING
Early bezels are heavy!

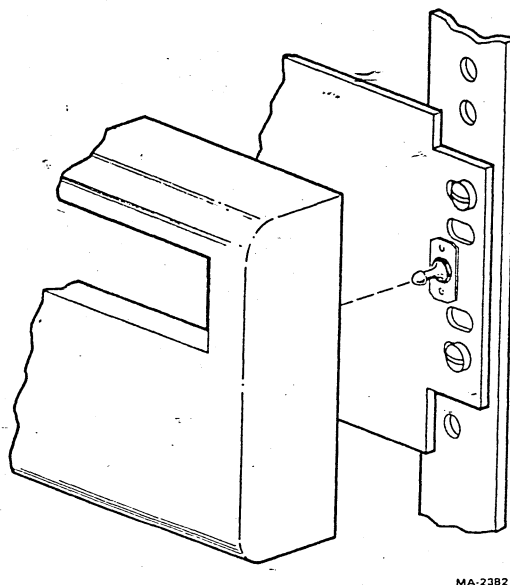

Figure 4-1 Bezel and Clip

If the rack requires them, install four speednuts at the holes spaced according to Figure 4-2. The TU58 is light enough for one person to install. Put the two bottom screws in first to avoid bending the mounting ears.

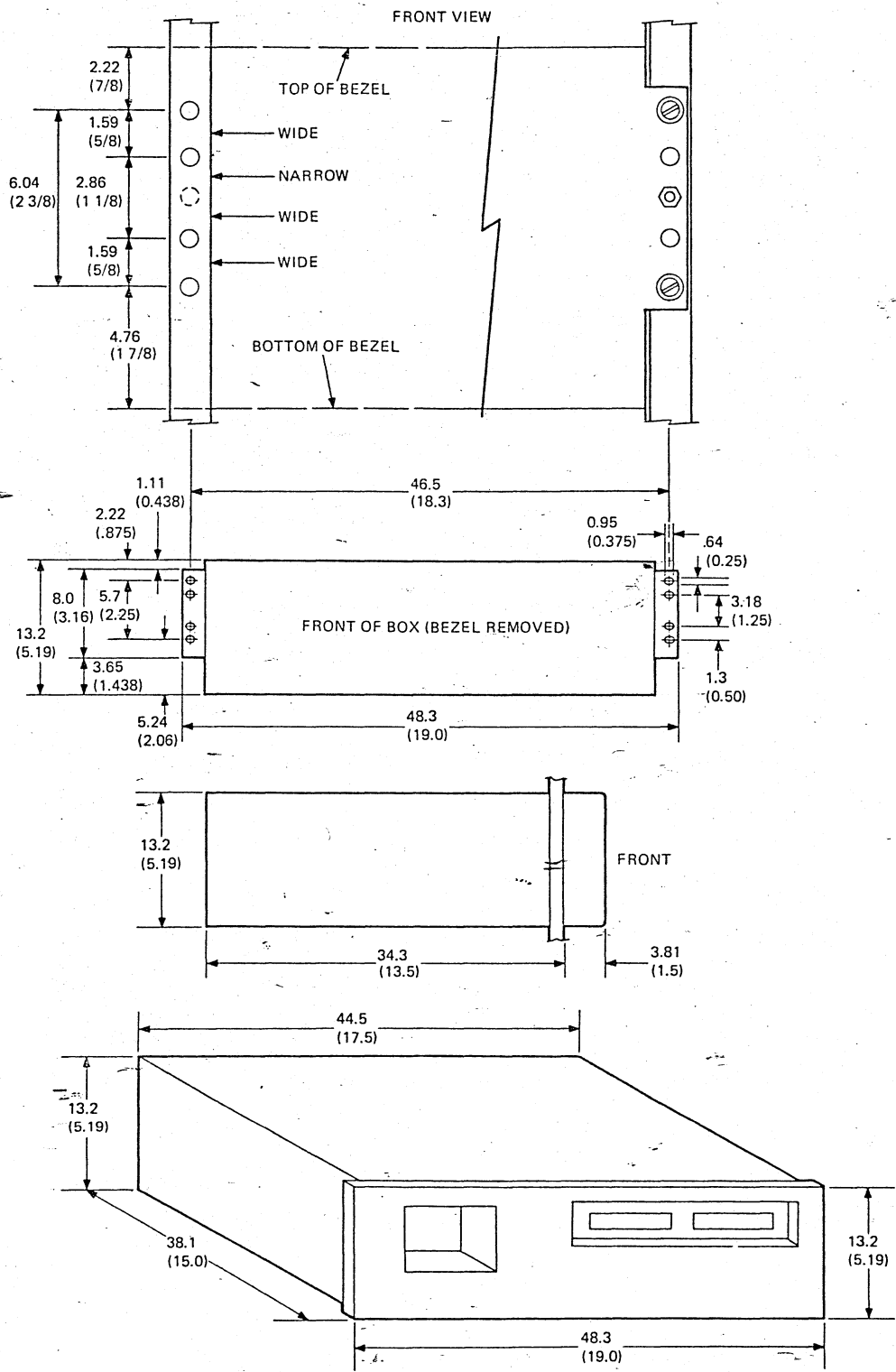

Figure 4-2 Rack Mounting the TU58-CA

4.1.2 Power Selection for the Rack Version

A line cord for 110 V and two fuses are supplied with the TU58-CA. Line cords for other voltages and standards may be purchased separately. The chassis power receptacle meets European IEC standards. A switch on the back of the rackmount cabinet selects 110 or 220 V (Figure 4-3).

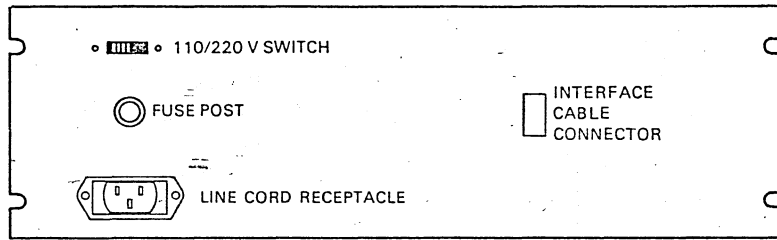

Figure 4-3 TU58-CA Rear Panel

1. Set the switch to the correct value using a small screwdriver.

CAUTION

If the unit is plugged into a 220 V circuit while set for 110 V, it may be severely damaged.

2. Install a fuse in the fuse post.

NOTE

A 3/8 A slow-blow fuse is required for 220 V, a 3/4 A slow-blow fuse for 110 V.

3. Insert the appropriate power cord into the receptacle. Do not plug it into an outlet until the installation is complete.

4.1.3 Removing Module From Chassis

The drive and module mounting cage must be pulled forward for the module to clear the bottom of the rack cabinet (Figure 4-4).

1. Unplug the power, drive, and interface connectors.

CAUTION

Be careful around the thin tachometer disk. It is easily bent (and its edge is sharp). If the disk gets bent without creasing, it might be straightened with pliers. Alignment is not critical, but it is better if the disk does not rub against the optical sensor block. It cannot be aligned, or if it is creased, it must be replaced.

2. Lift one of the spring-metal catches at the bottom left or right edges of the cage and pull that side of the cage forward just enough to clear the catch.
3. Release the other side in the same way.
4. Slowly pull the cage forward about 5 cm (2 in).
5. Unlatch the module handle locks and pull the module out. The loose cage may be tilted to provide clearance.

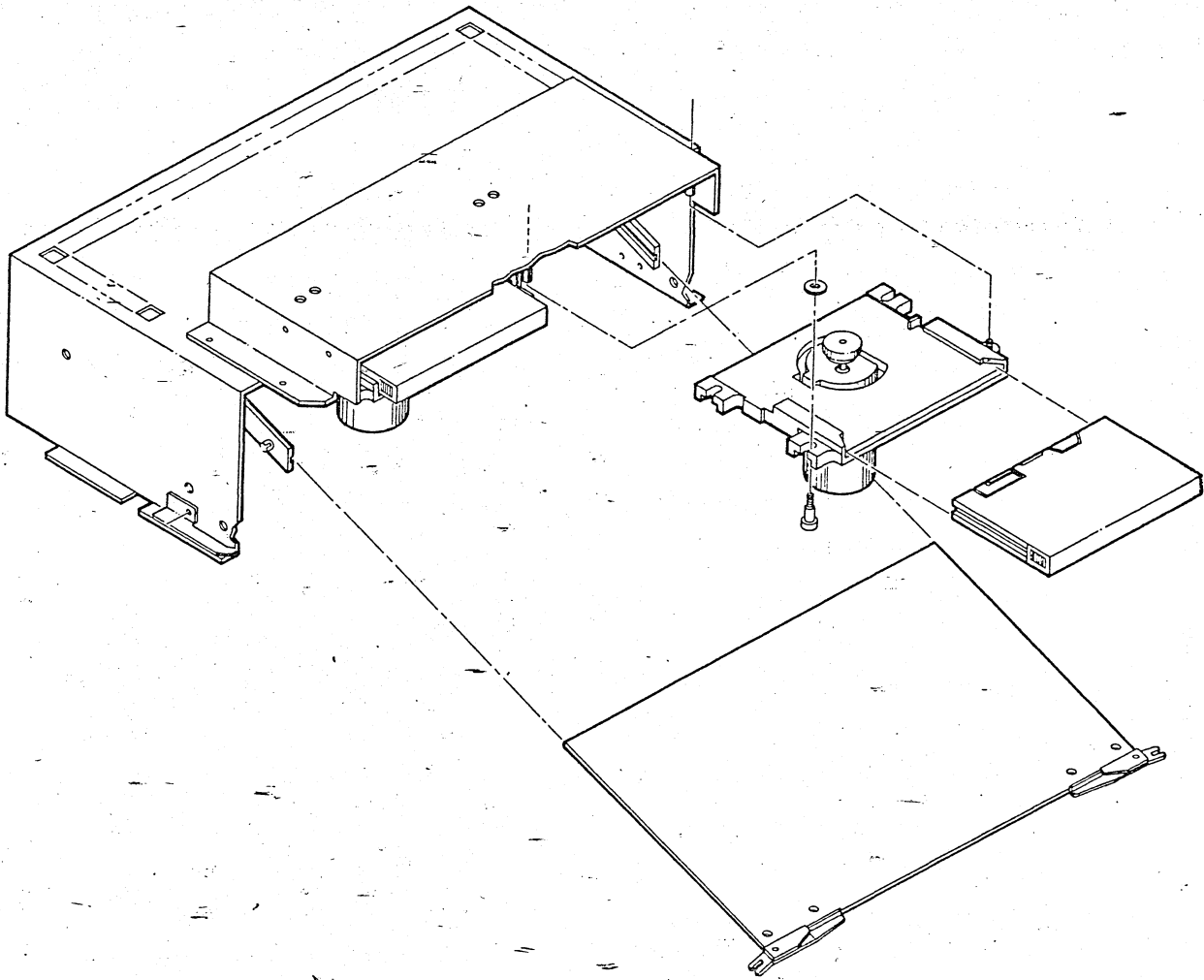

MA-2365

Figure 4-4 Module Removed from Chassis

4.1.4 Reinstalling the Module

1. Slide the module into the guides in the cage, lifting the drive cables out of the way. (This may be done with the cage removed from the rack.) Do not latch the module into place yet.
2. Plug the drive cables into the module headers, left drive to left header and right to right. The plugs are keyed and install with the cables attached to them from the rear of the cabinet.
3. Set the cage on the edge of the cabinet and reach behind to the power supply cable. Thread the cable into the cage over the module. The three keying fingers are on the left as the plug goes onto the power header on the module.
4. Push the module firmly into the cage and latch it into place.
5. The interface cable enters the rackmount cabinet through a connector on the back panel. Draw the flat interface cable forward under the module and cage and arrange it so that the connector can fit into the header without twisting the cable. The red stripe is on the left and the cable goes into its connector from below.
6. Dress the cable so that it is not crimped under the cage edges and line the four cage ears with the punched tabs in the cabinet bottom plate. Push the cage back into the tabs until the spring catches click.

4.2 DRIVE AND MODULE INSTALLATION (DOES NOT APPLY TO RACKMOUNT)

Figures 4-5 and 4-6 provide the mounting dimensions for the circuit board (module) and drive mechanism. The drive has a 19 cm (7.5 in) cable which plugs into the module header with the wires coming out of the plug toward the center of the module. The plug is keyed to ensure proper orientation. The cartridge extends 1.60 cm (0.62 in) from the front of the drive. If the drive is recessed in a panel, clearance must be provided around the opening for fingers to grip the cartridge. Ideally, the cartridge slot in a front panel will be somewhat larger than minimum, to allow easy insertion. The opening should be at least the dimensions of the cartridge, 1.3 cm (0.5 in) × 8.1 cm (3.2 in), located not more than 0.53 cm (0.17 in) above the bottom mounting surface (line A in Figure 4-8).

The module should be mounted on a flat surface with 3 mm (6/32 in) hardware and 1 cm (3/8 in) standoffs. Both the module and the drive may be mounted at any angle. For mounting from above, the drives require 1.80 cm (0.71 in) clearance; hole spacing is given in the outline drawings. For mounting from below, the drives require an 8.18 cm (3.22 in) × 8.89 cm (3.50 in) chassis cutout, with the same mounting hole spacing.

CAUTION

The mounting surface for the drives must be flat within 0.64 mm (0.025 in).

4.3 INTERFACE STANDARDS SELECTION AND SETUP

The TU58 is shipped with factory-installed jumpers for a transmission rate of 38.4 kilobaud and the RS-423 unbalanced line interface. A variety of standards and rates may be selected by changing the jumpers on the controller module. Table 4-1 provides a list of all the pins on the board and their functions, including the wire-wrap (WW) pins, interface, and power connectors.

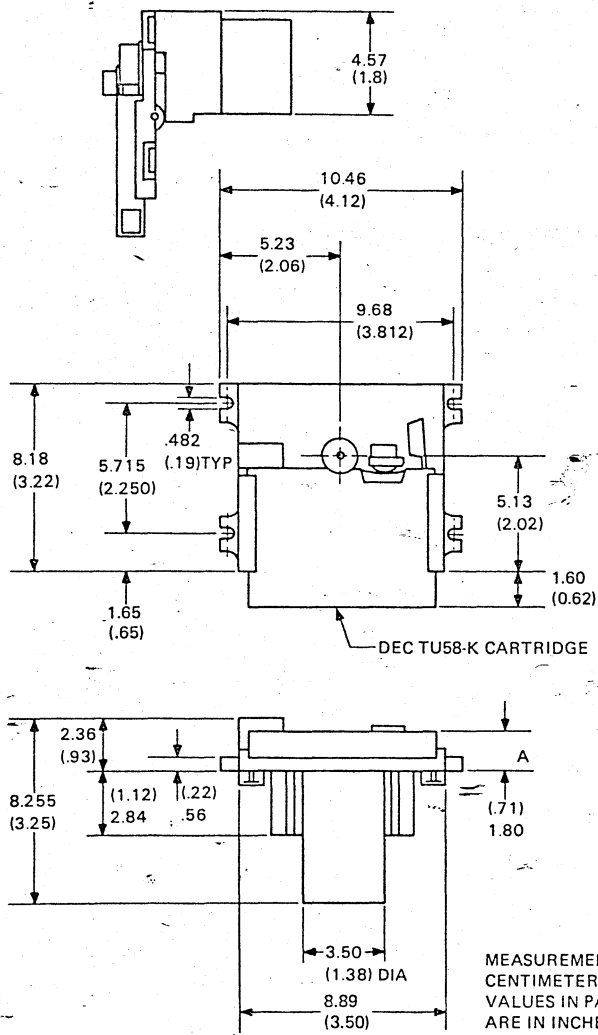
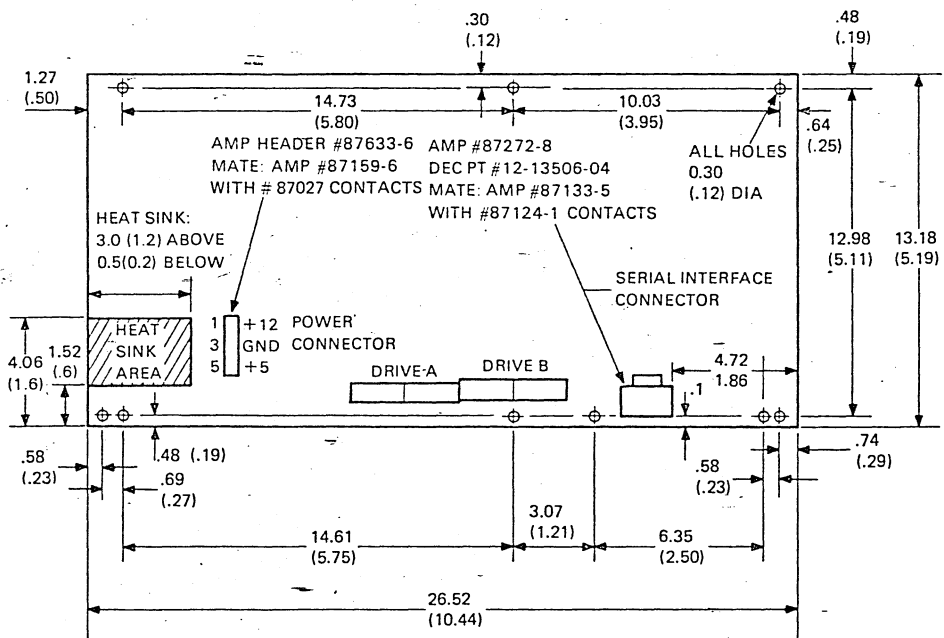

Figure 4-5 Drive Outline Drawings



MEASUREMENTS ARE IN
 CENTIMETERS EXCEPT VALUES IN
 PARENTHESES ARE IN INCHES

MA-2370

Figure 4-6 Module Outline Drawing

Table 4-1 TU58 Module Connections

Wire-Wrap Pins

WW1	150 Baud	
WW2	300 Baud	
WW3	600 Baud	
WW4	1200 Baud	
WW5	2400 Baud	
WW6	4800 Baud	
WW7	9600 Baud	
WW8	19200 Baud	
WW9	38400 Baud	
WW10	UART Receive Clock	
WW11	UART Transmit Clock	
WW12	Auxiliary A (to interface connector pin L)	
WW13	Auxiliary B (to interface connector pin A)	
WW14	Factory Test Point	
WW15	Ground	} Connect together for auto-boot on power-up.
WW16	Boot	
WW17	RS-423 Driver	
WW18	RS-423 Common (Ground)	
WW19	Transmit Line +	
WW20	Transmit Line -	
WW21	RS-422 Driver +	
WW22	RS-422 Driver -	
WW23	Receiver Series Resistor (Jump for RS-422)	
WW24		

Serial Interface Connector

J2-A	Auxiliary B	J2-H	Transmit Line -
J2-B	Ground	J2-J	Transmit Line +
J2-C	Receive Line +	J2-K	Ground
J2-D	Receive Line -	J2-L	Auxiliary A
J2-F	Ground		

Power Input Connector

J1-1	+12 V
J1-3	Ground
J1-5	+5 V
J1-6	-Ground

Drive Cable

J3,4-1	Cart L	J3,4-9	LED
J3,4-2	No Connection	J3,4-10	Head Shield Ground
J3,4-3	Permit L	J3,4-11	Erase Return
J3,4-4	Signal Ground	J3,4-12	Erase 1
J3,4-5	Motor +	J3,4-13	Erase 0
J3,4-6	Motor -	J3,4-14	Head Return
J3,4-7	+12 V	J3,4-15	Head 0
J3,4-8	Tachometer	J3,4-16	Head 1

4.3.1 Selecting Interface Standards

The serial interface operates on full-duplex, asynchronous 4-wire lines at rates from 150 baud to 38.4 kilobaud. The transmit and receive rates may be independently set. Each 8-bit byte is transmitted with one start bit, one stop bit, and no parity. The line driver and receiver may be set to operate in accordance with EIA RS-422 balanced or RS-423 unbalanced signal standards. When set to RS-423, the TU58 is compatible with devices complying with RS-232-C.

The TU58 is shipped prewired for operation at 38.4 kilobaud transmit and receive on RS-423. The maximum wire length that may be used at that data rate in an electrically quiet environment like an office is approximately 27 m (90 ft). The wire used with any installation should be no less than 24 AWG diameter.

Longer wire runs may be made if data rates are reduced. RS-422 is considerably more noise-immune than RS-423 and can be used over at least 1200 m (4000 ft) at any TU58 data rate. Figure 4-7, derived from the EIA standards, illustrates the variations in distance needed by RS-423 for different data rates. For more information, consult the standards for RS-422 and RS-423 published by the Electronic Industries Association.

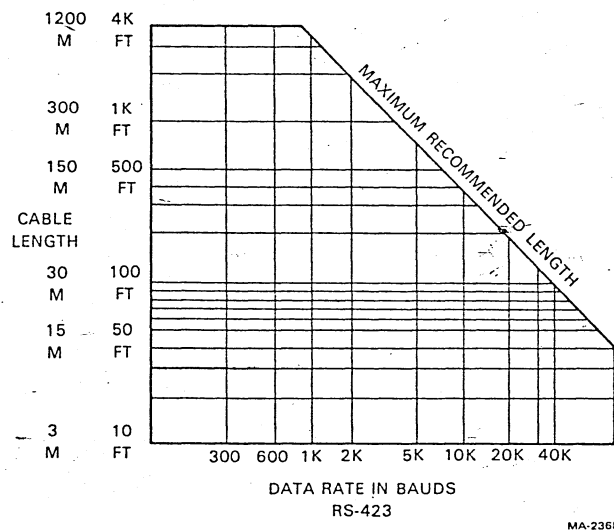

Figure 4-7 Data Rate and Cable Length for RS-423

4.3.2 Connecting Standards Jumpers

The jumper pins are standard 0.635 mm (0.025 in) wire-wrap posts which may be connected using 30 AWG wire and a hand tool. Other techniques that may be used include slip-on connectors such as DEC H821 Grip Clips, 915 patchcords, 917 daisy-chain, or soldering.

The baud rates may be set independently for transmission and reception, or both can operate together. Simply connect the pin with the desired baud value to either the XMIT or RCV pins or both. Figure 4-8 illustrates the pin locations, and Figure 4-9 shows the factory-wired configuration.

The interface standards may be selected by connecting sets of pins together. The connections are listed in abbreviated form in Figure 4-8. The group of pins 17 through 24 are the interface pins. The module is shipped prewired for RS-423 with pin 17 connected to pin 19, and pin 18 connected to pin 20. No other pins in the group are connected.

For RS-422, pin 21 should be tied to pin 19, pin 22 to pin 20, and pin 23 to pin 24. No other pins in the group are connected.

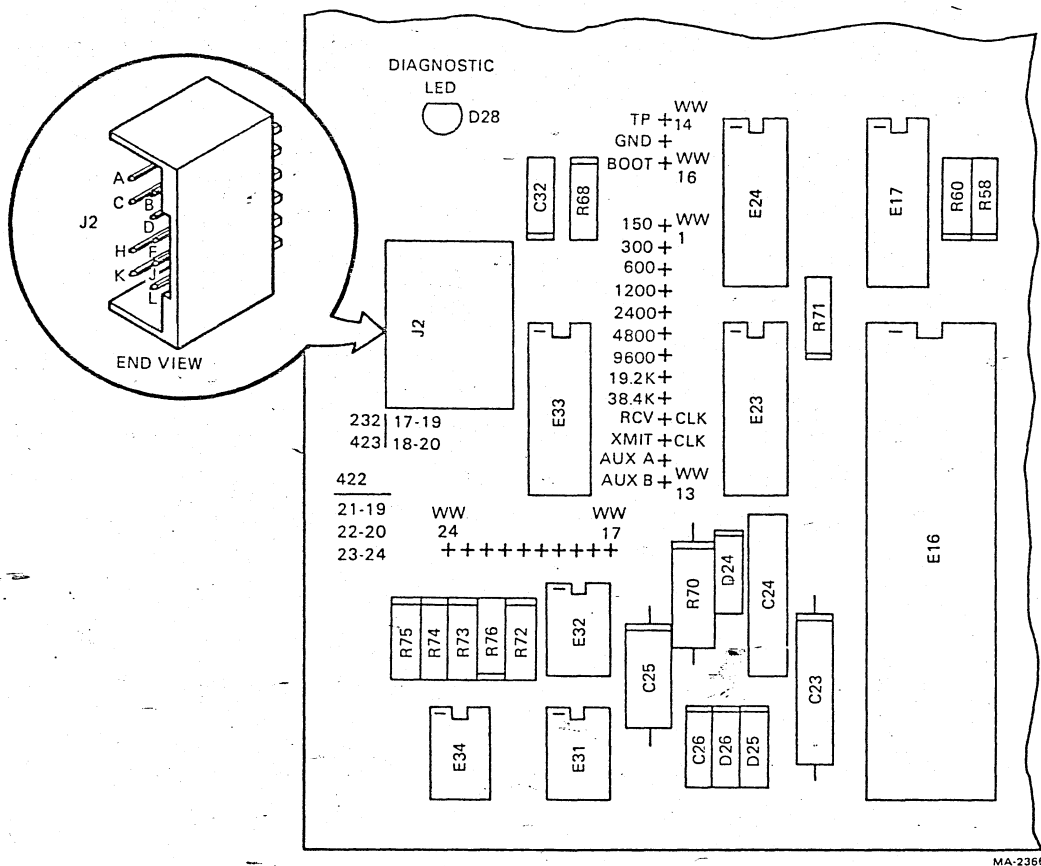

Figure 4-8 Interface Selection Jumper Pin Locations

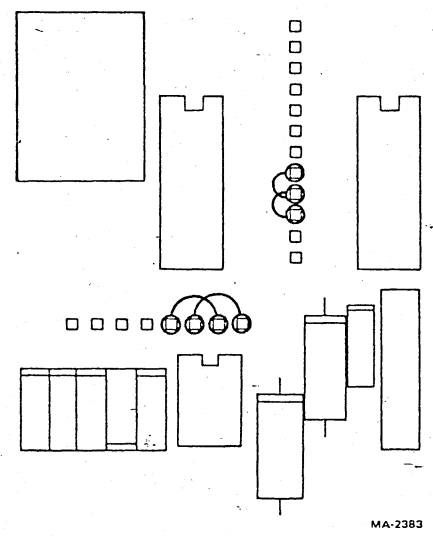

Figure 4-9 Factory Wiring

4.4 OPERATIONAL CHECKOUT

A confidence check of the operation of the newly installed TU58 may be performed through the console or keyboard console emulator of a host system without the use of an operating system device handler. The light on the TU58 module should be on, indicating a functional processor.

4.4.1 Checkout of Interface

To address the serial interface device registers with the console (consult the system manuals for addresses and codes), perform the following steps.

1. Set the transmit control status register to send Break to the TU58.
2. Remove the Break condition.
3. Transmit INIT: 04 (octal) to the TU58.
4. Transmit a second 04.
5. Examine the receive data buffer to find Continue: 20 (octal).

4.4.2 Checkout of RSP and Command Function

1. Insert a tape cartridge into drive 0 (left side).
2. Transmit the following string of octal numbers to the TU58. (Consult the programming chapter for an explanation of this format.)

Byte 1	2
Byte 2	12
Byte 3	2
Byte 4	0
Byte 5	0
Byte 6	0
Byte 7	0
Byte 8	0
Byte 9	0
Byte 10	200
Byte 11	200
Byte 12	0
Byte 13	204
Byte 14	212

The TU58 should wind to the beginning of the tape and read about half of the tape.

CHAPTER 5 OPTIONS

Options may be added to the 11/58 to enhance its product performance. These additions are described in this chapter.

5.1 RUN INDICATOR

Each tape drive may be modified to have an LED which lights to indicate tape motion. Since data loss can occur if a cartridge is removed while the tape is being written, the cartridge should not be touched if the light is on.

5.1.1 Installation

The LED (which may be any device capable of handling 30 mA with a forward voltage less than 1.8 V) is wired in series with the tachometer source LED. Splice the run LED into the wire from pin 7 of the drive connector. (Count from the end with the missing pin. That pin is number 2.) The anode should be on the module side of the wire (symbol arrow pointing away from pin 7). See Figure 5-1. The LED is available from DEC as part number 11-10324, and wires with slip connectors are available to join the LED to the track (cable number 70-16526) and to extend the module connector end to the LED at the front of the drive (cable number 70-16525).

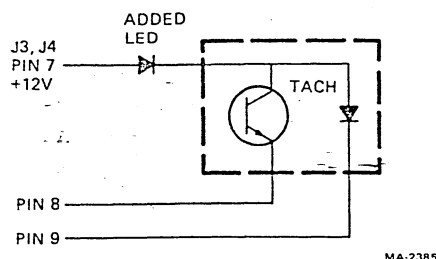
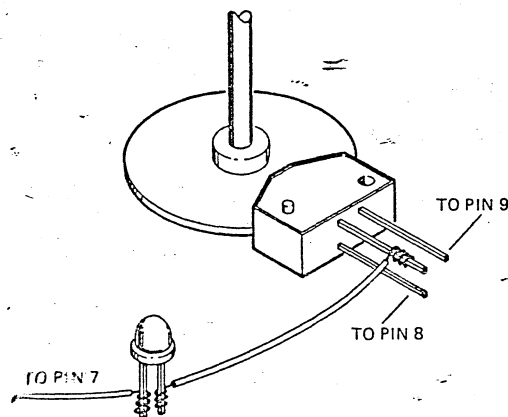

Figure 5-1 Installation of Run Indicator

5.2 BOOT SWITCH

Some applications use the TU58 as a program loader. The intelligence of the TU58 enables it to perform a seek and read operation without processor commands. Pins are available on the controller module which, when connected by the Boot switch, initiate the following actions.

1. On power-up, the TU58 checks for the presence of the closed switch. It then delays 1 second and begins the boot procedure.
2. When the TU58 is in the idle state, it monitors the Boot switch. Any switch contact open-close sequence causes a 1-second delay (to allow for contact settling or to allow the host processor to enter the halt mode), and then the TU58 begins the boot procedure.

The boot procedure positions the tape in drive 0 to block 0, sends Break to the host, and transfers ASCII characters from the tape to the host in groups of seven. Each group is separated from the adjacent groups by 15 character times (based on 9600 baud). The TU58 exits the boot mode following the transfer of the terminating character ASCII G (147₈) and enters the idle state. Because of the timing requirement, only rates of 9600, 19.2, and 38.4 kilobaud may be used with boot.

Boot is intended for use with the LSI-11. The boot tape contents are formatted to appear to the LSI-11 as output from a console (keyboard) operating under the ODT keyboard interpreter. This means that the TU58 must be located at the standard console address in the LSI-11 bus. A keyboard cannot be connected at the same time. This arrangement is useful in an unattended control system, where the TU58 can automatically load and start or reload and restart an unsupervised process controller or similar application. The Boot switch allows a reboot without powering down to cycle the automatic sequence.

NOTE

Boot mode does not work in any DEC operating system environment.

A utility program running under RT-11 will be available from DEC which will take a user program that was developed under RT-11 and generate a boot tape containing that program, suitable for automatic loading.

The boot pin on the module (WW16) may be connected to ground (WW15) through a normally closed momentary action switch (Paragraph 4.4.2). Wires may be wire-wrapped, DEC Grip-Clipped, or soldered to the pins. Placement of the switch and lead dress are not critical if adequate clearance is provided around moving parts of the drive and the heat sink and power resistors on the module.

TU58 User Guide Additions and Mistakes

Maintenance Mode

See following page for addition.

Page 1-5, Figure 1-5

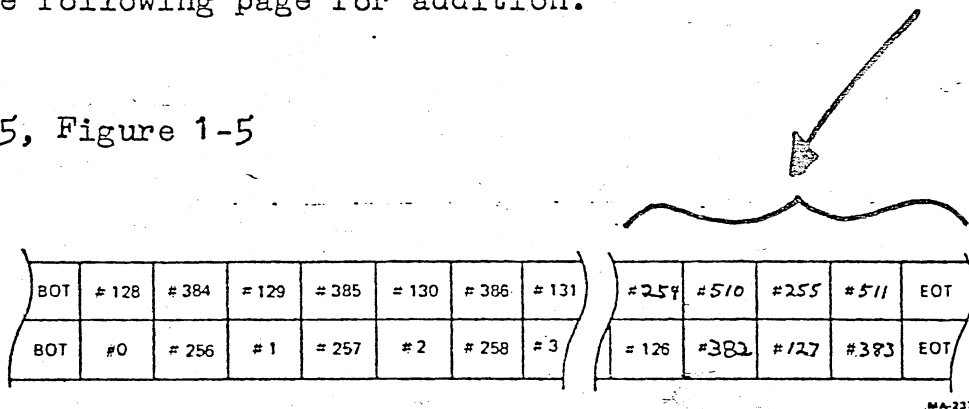

Figure 1-5 Block Locations on Tape

Page 3-6 NOP

OP CODE 0 NOP

This instruction causes the TU58 to return an end packet. There are no modifiers to NOP. The NOP packet is shown below.

BYTE				
0	0000	0010	FLAG	
1	0000	1010	MESSAGE BYTE CNT	
2	0000	0000	OP CODE	
3	0000	0000	MODIFIER	
4	0000	000X	UNIT NUMBER (IGNORED)	
5	0000	0000	SWITCHES (NOT USED)	
6	0000	0000	SEQ NO.	
7	0000	0000	SEQ NO.	NOT USED
8	0000	0000	BYTE COUNT L	NO DATA INVOLVED
9	0000	0000	BYTE COUNT H	NO TAPE POSITION
10	0000	0000	BLOCK NO. L	
11	0000	0000	BLOCK NO. H	
12	0000	001X	CHECKSUM L	
13	0000	1010	CHECKSUM H	